

Art. Nr. 100250

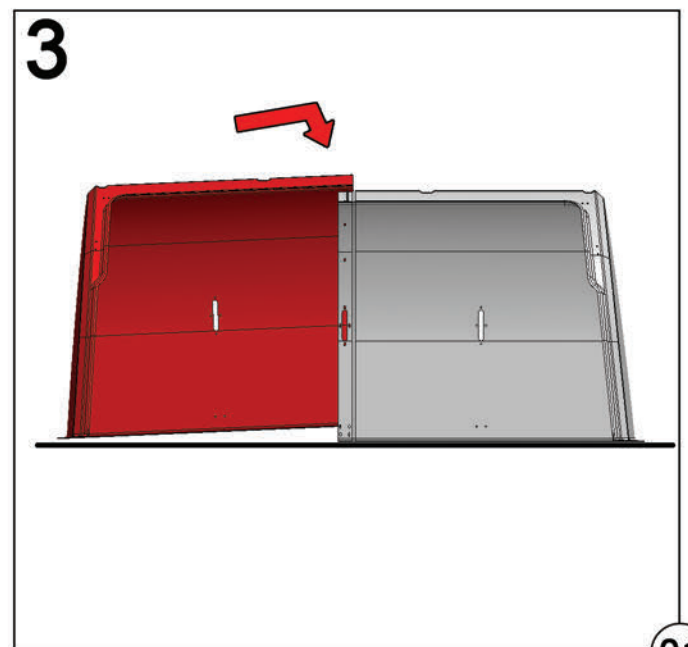

A	M8x30	12x	D	1x
B	18x		E	1x
C	12x		F	1x
G				1x

© Rights reserved by VDK Products B.V. WWW.CALFOTEL.COM 01-2019

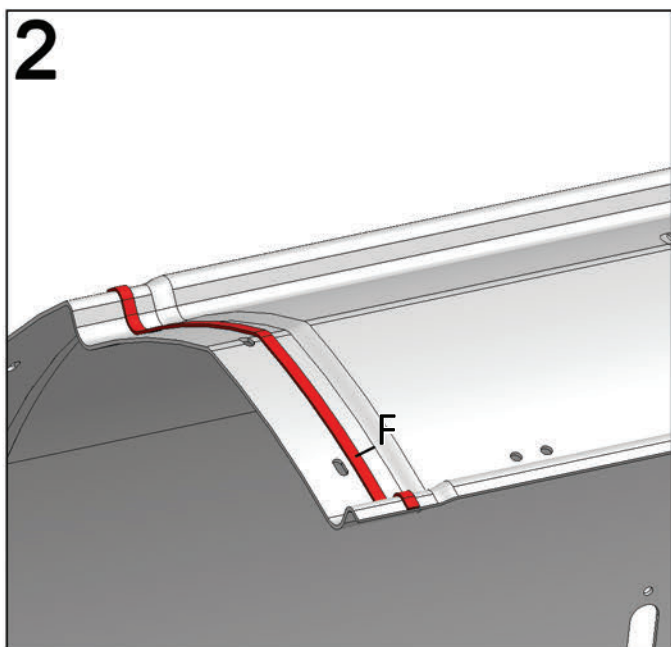
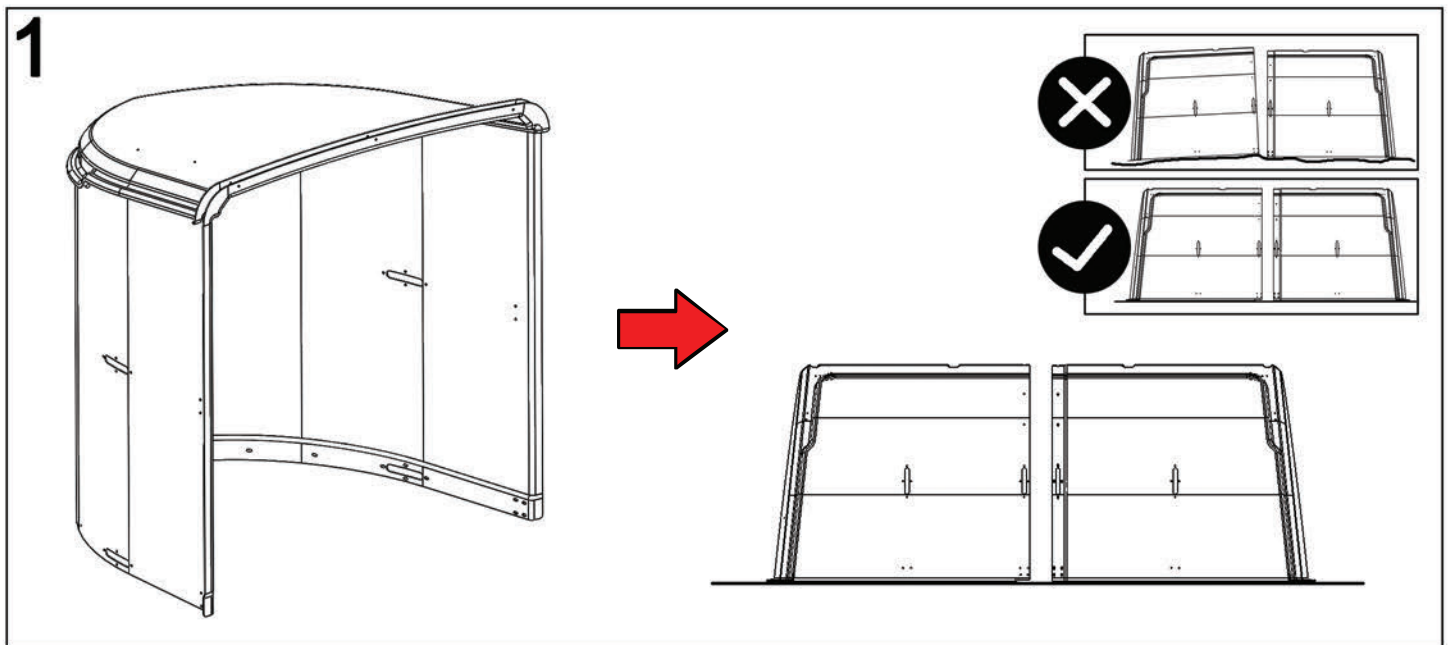

ENG. Assemble nut by hand, do not fully tighten.

NL. Monteer de moer met de hand, niet geheel vast draaien.

FR. seulement assembler l'écrou à la main, ne pas serrer complètement.





DU. Montieren Sie die Mutter nur von Hand, ziehen Sie sie nicht vollständig.

Art. Nr. 100250

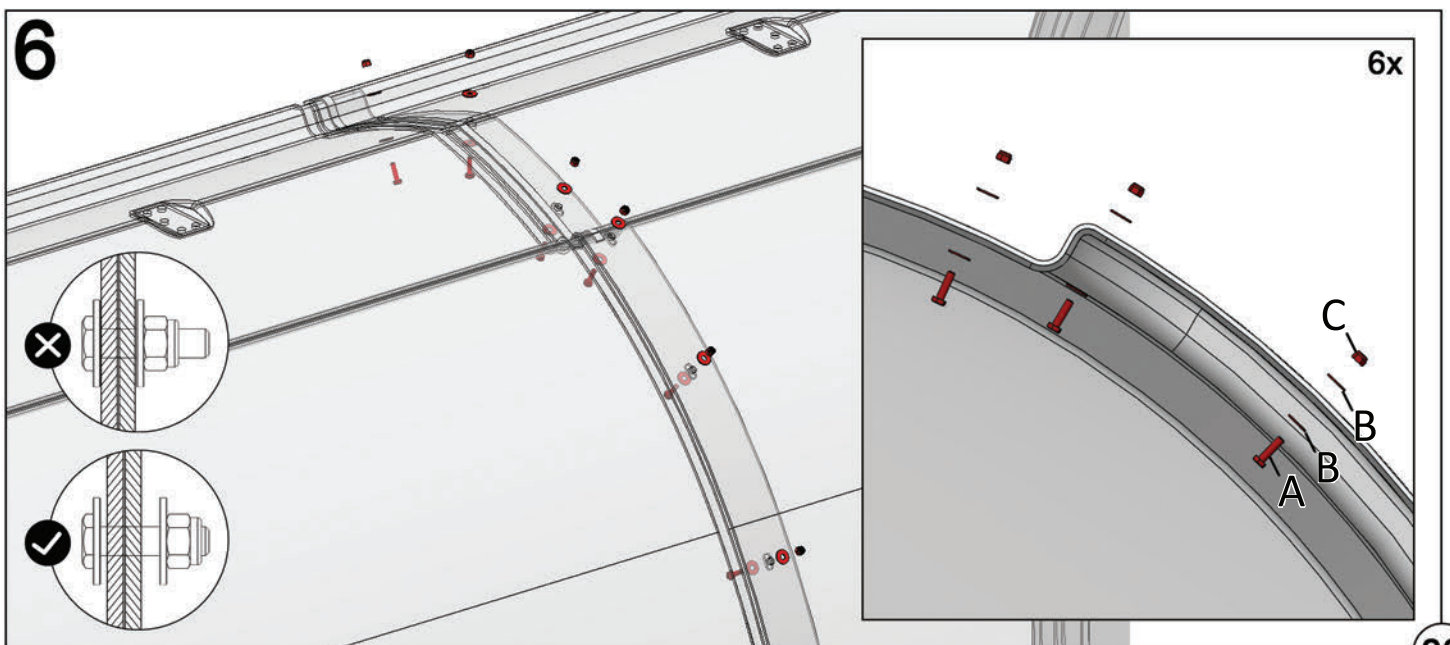
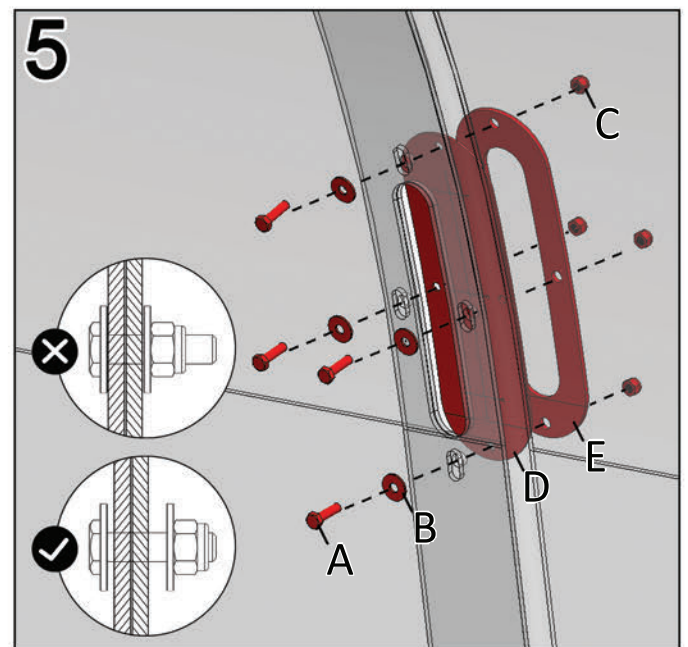
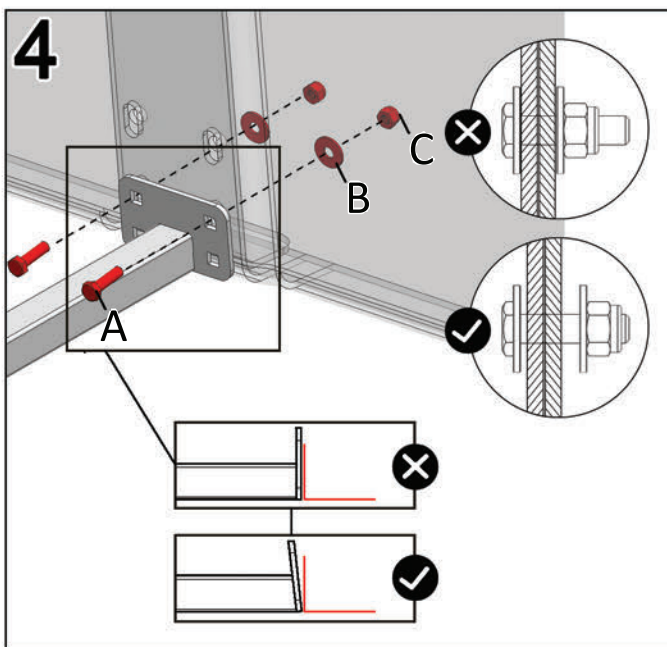

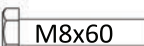
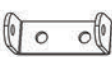
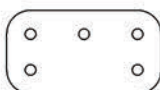
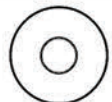
© Rights reserved by VDK Products B.V. WWW.CALFOTEL.COM 01-2019



<b>2</b>	E  2x
A  10x	F  2x
	G  2x
C  16x	H  2x
D  10x	J  2x

Art. Nr. 100250

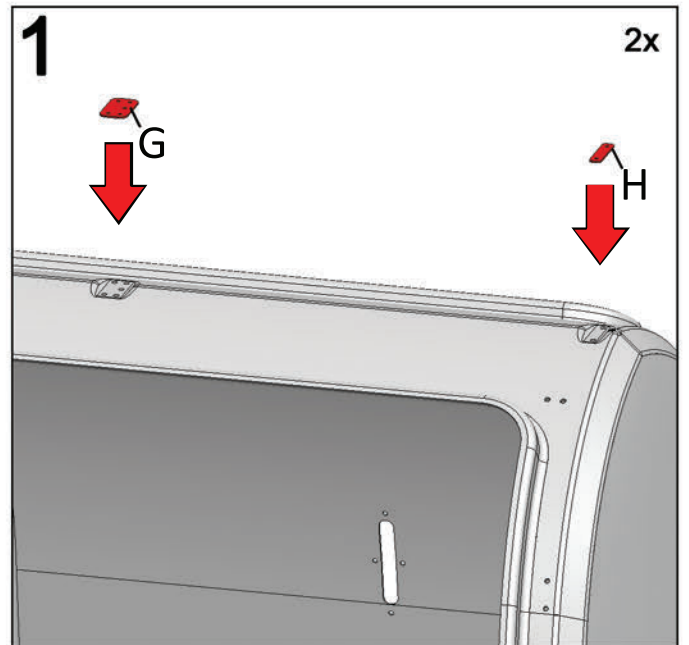

© Rights reserved by VDK Products B.V. WWW.CALFOTEL.COM 01-2019

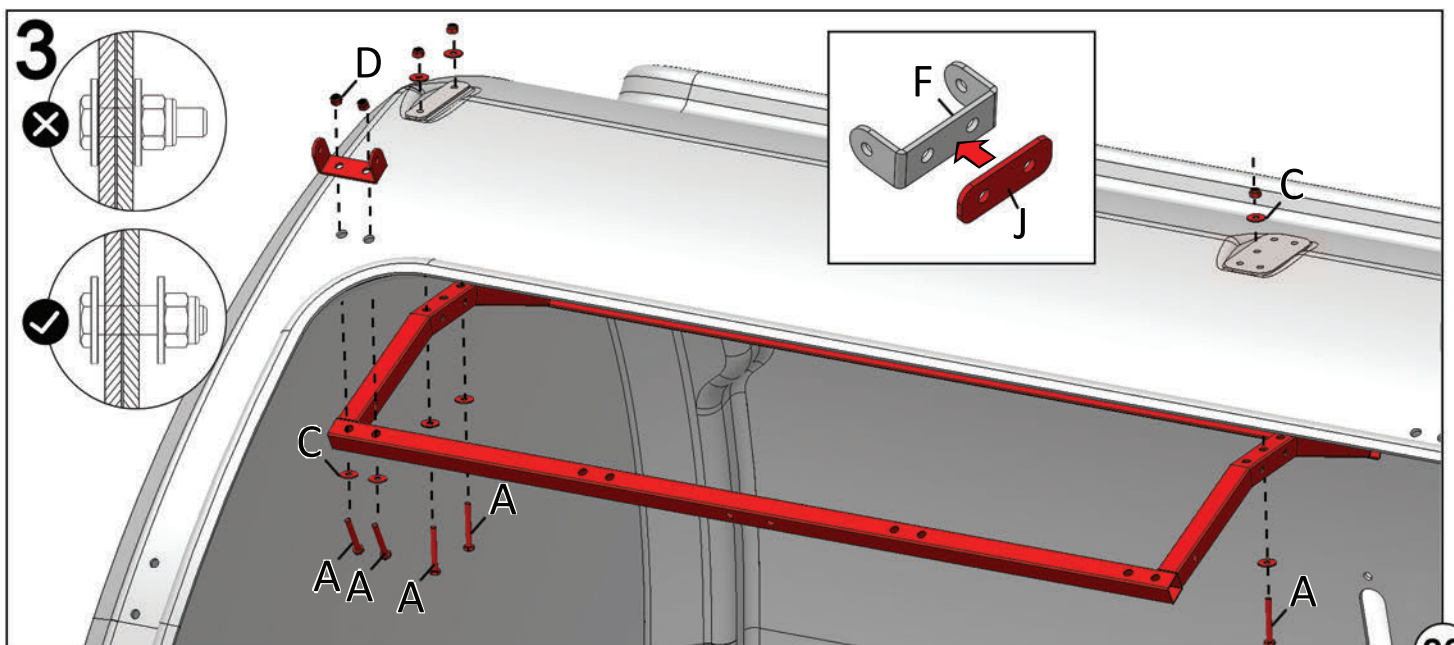
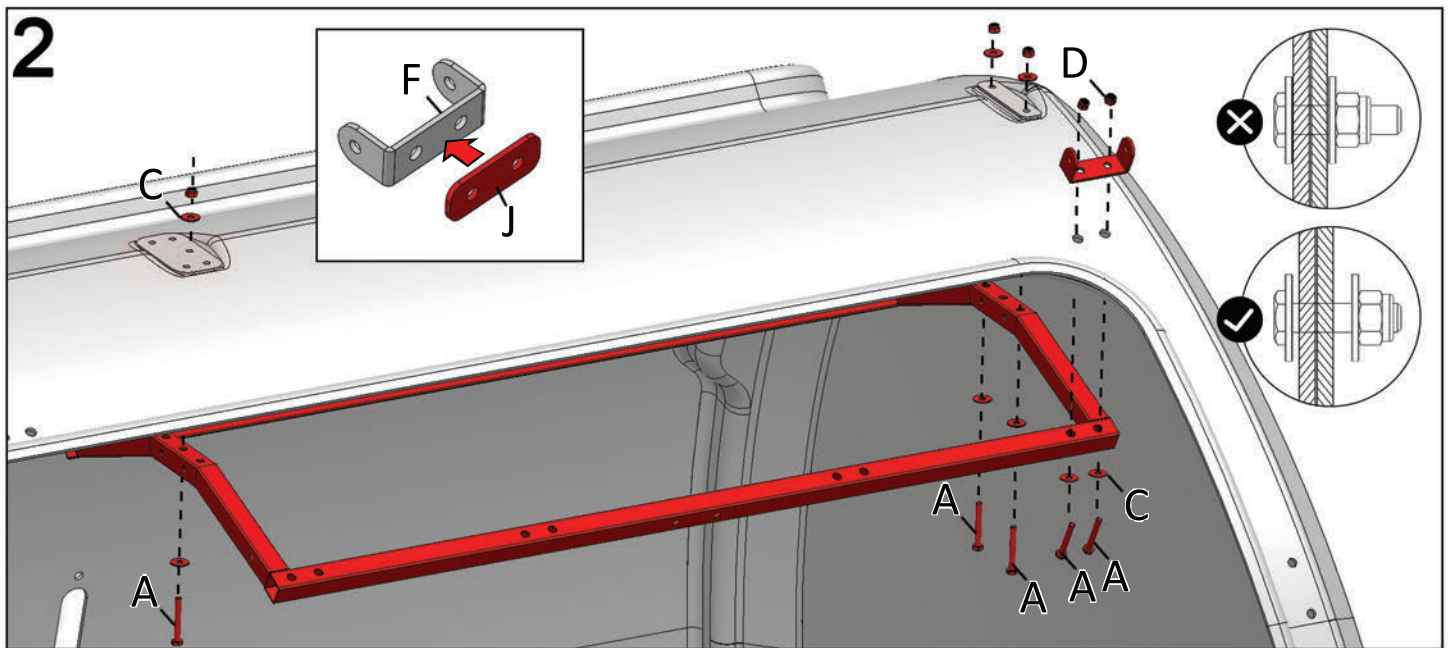

<b>3</b>			
A	M8x80 8x	G	2x
		H	1x
C	M8x30 8x	J	2x
D	M8x60 12x	K	2x
E	12x	L	2x
F	28x	M	4x

Art. Nr. 100250

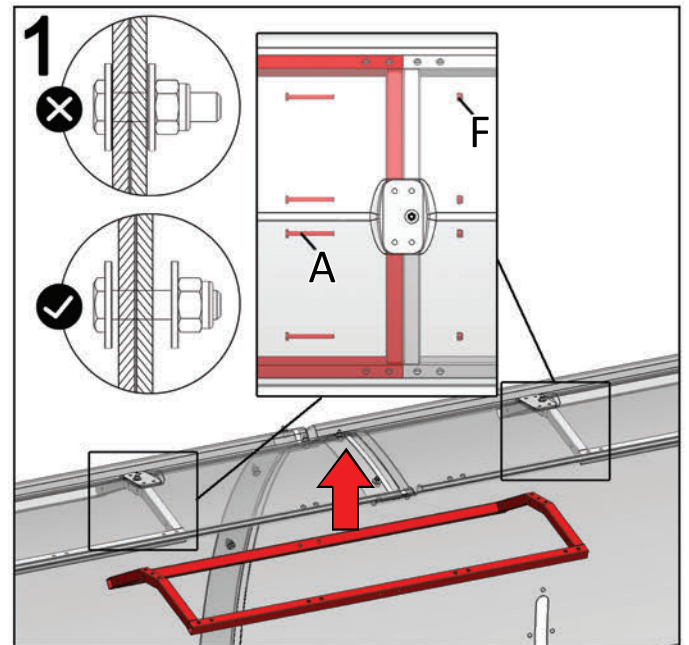

© Rights reserved by VDK Products B.V. WWW.CALFOTEL.COM 01-2019

**2**

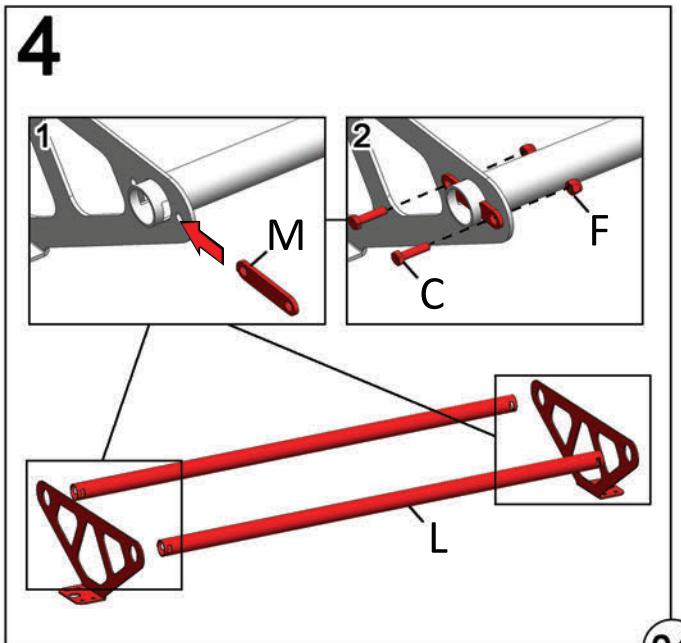
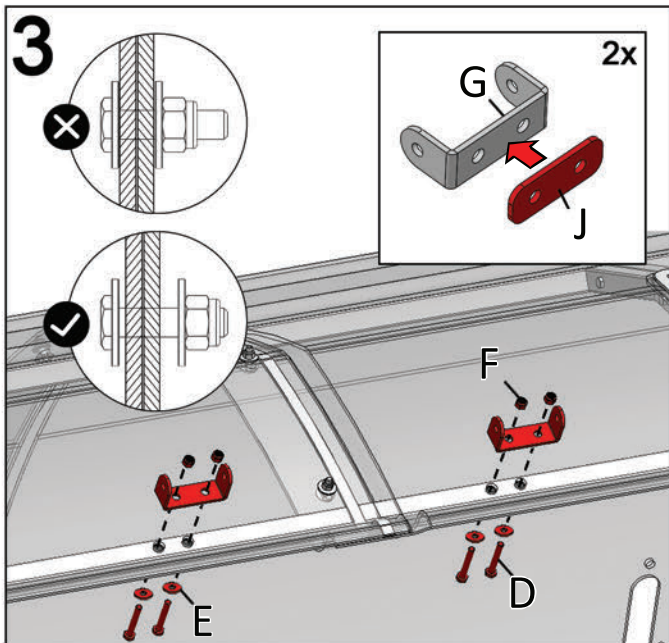
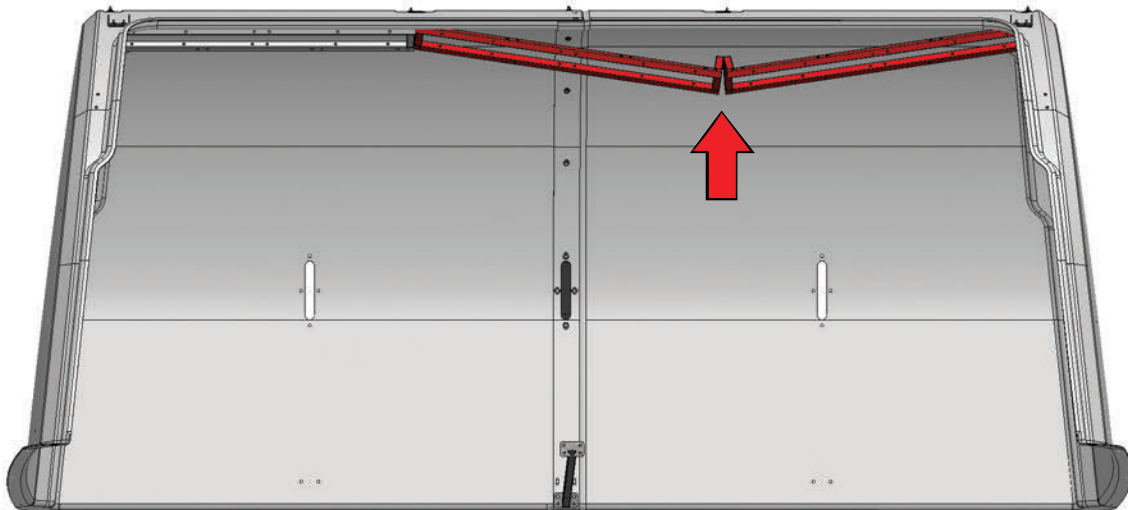

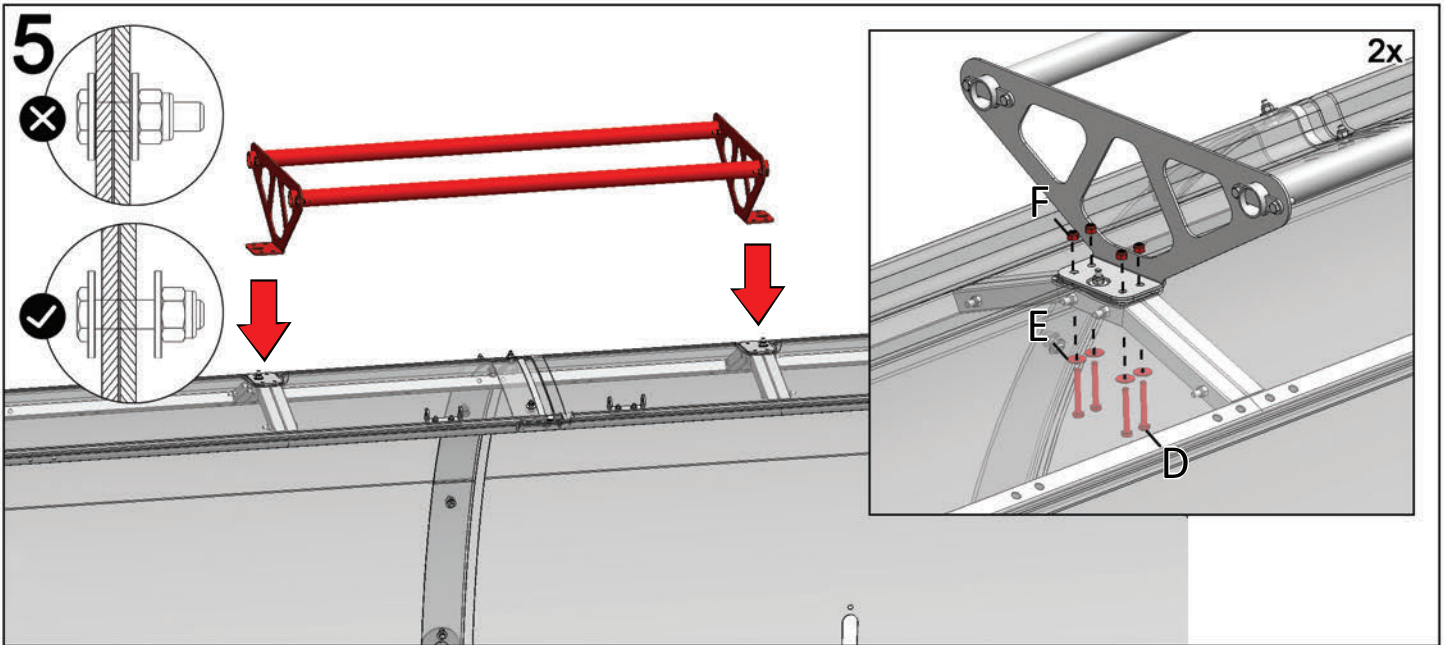

Art. Nr. 100250

**CALFOTEL**  
www.calfotel.com

© Rights reserved by VDK Products B.V. WWW.CALFOTEL.COM

01-2019

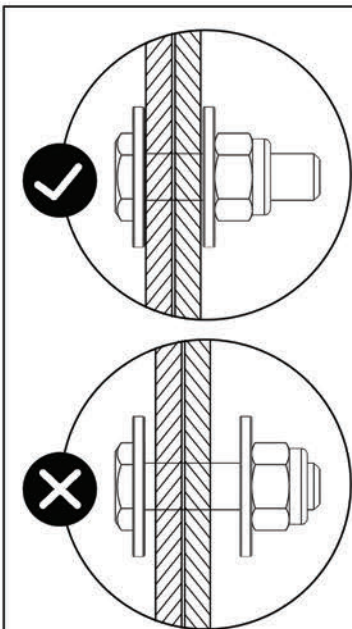

**ENG.** Now tighten the loose bolts in the following order.

**NL.** Draai nu alle losse bouten/moeren aan in de hierop volgende volgorde.

**FR.** Serrez maintenant les boulons desserrés dans l'ordre suivant.

**DU.** Ziehen Sie jetzt die losen Bolzen in der folgenden Reihenfolge fest.

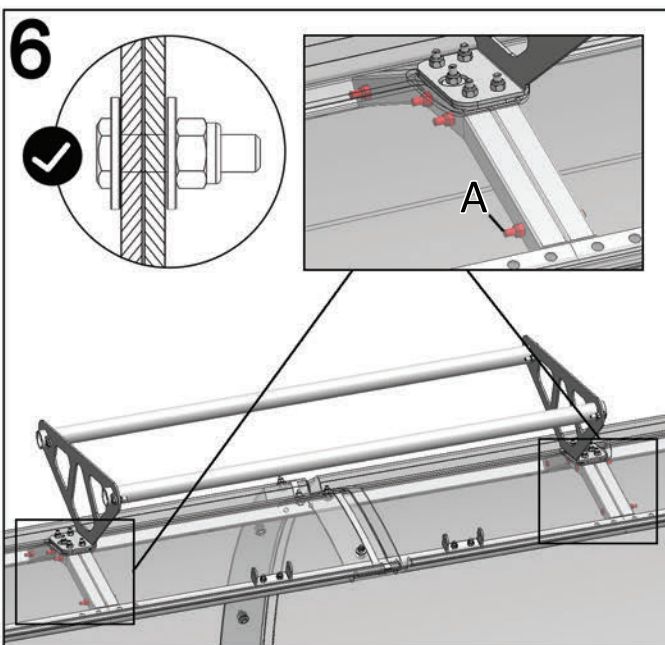

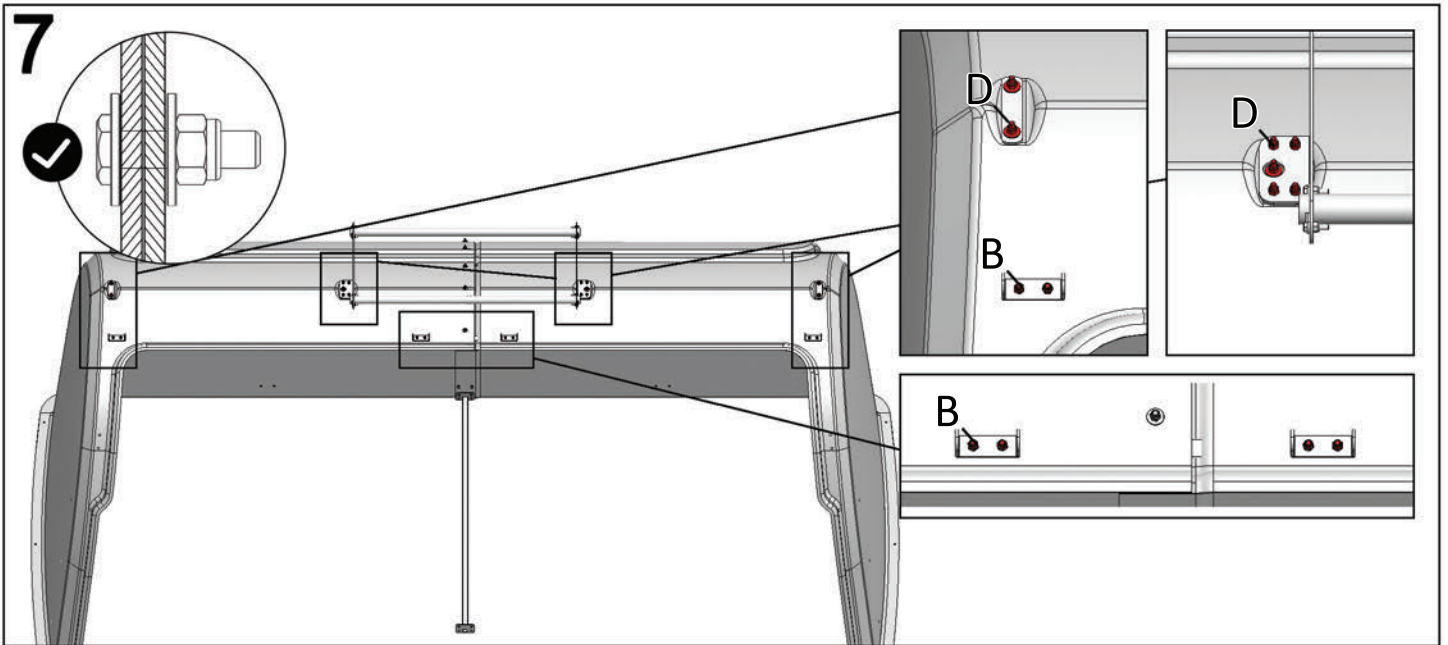







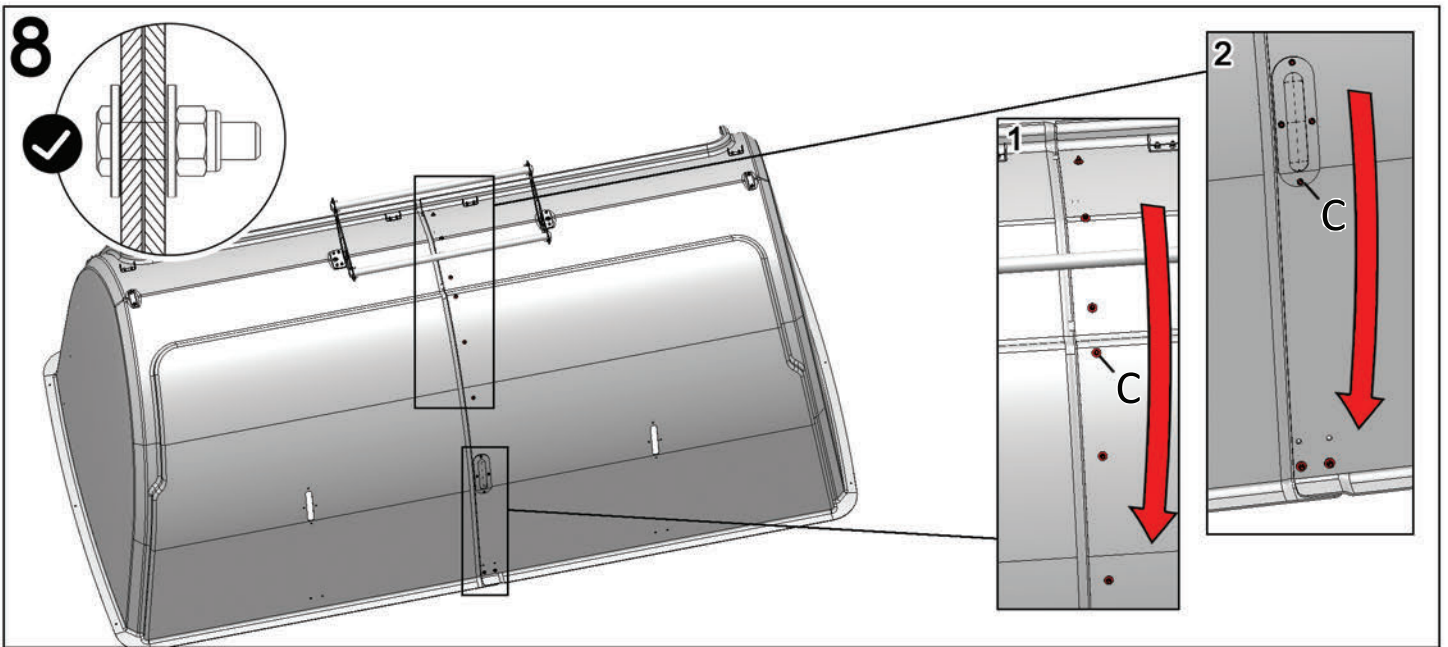





Art. Nr. 100250

**CALFOTEL**  
www.calfotel.com

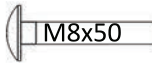
© Rights reserved by VDK Products B.V. WWW.CALFOTEL.COM 01-2019

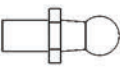

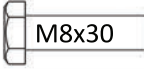
<b>4</b>		G  1x
A  M8x110 6x	H  2x	
B  10x	J  2x	
C  33x	K  2x	
D  M8x50 20x	L  1x	
E  3x	M  2x	
F  2x	N  M8x30 4x	

Art. Nr. 100250



© Rights reserved by VDK Products B.V. WWW.CALFOTEL.COM 01-2019

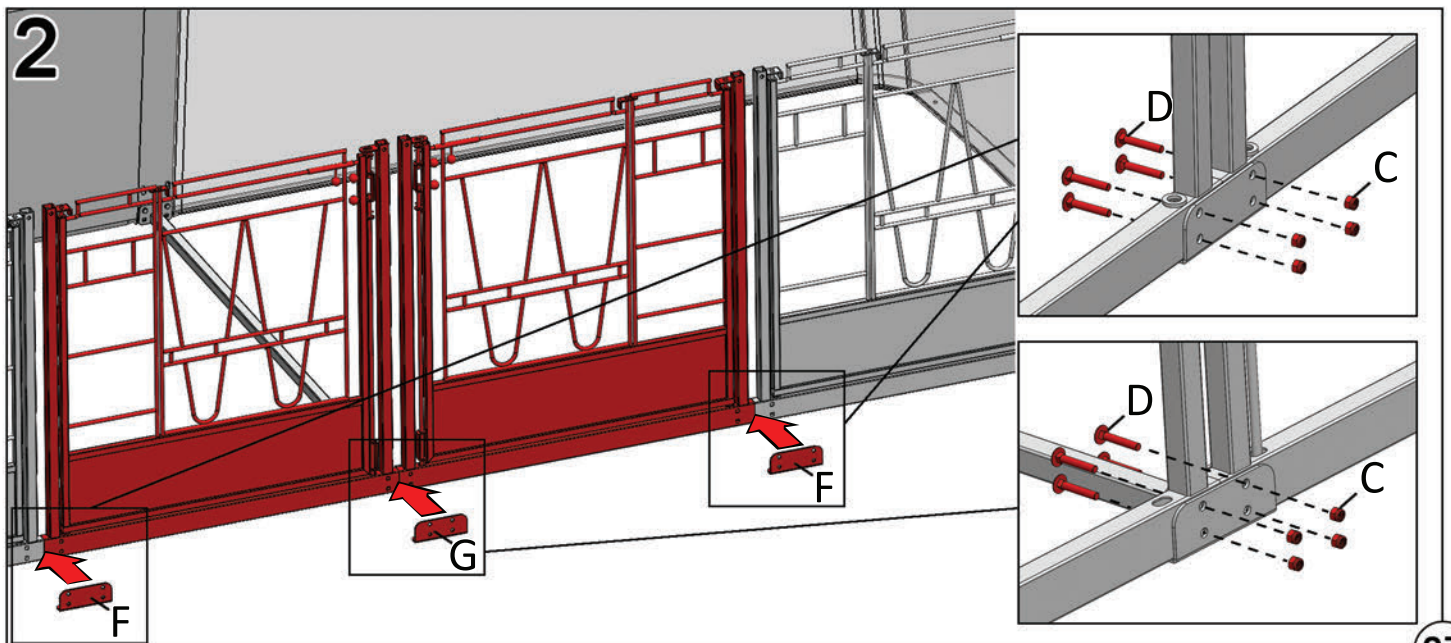
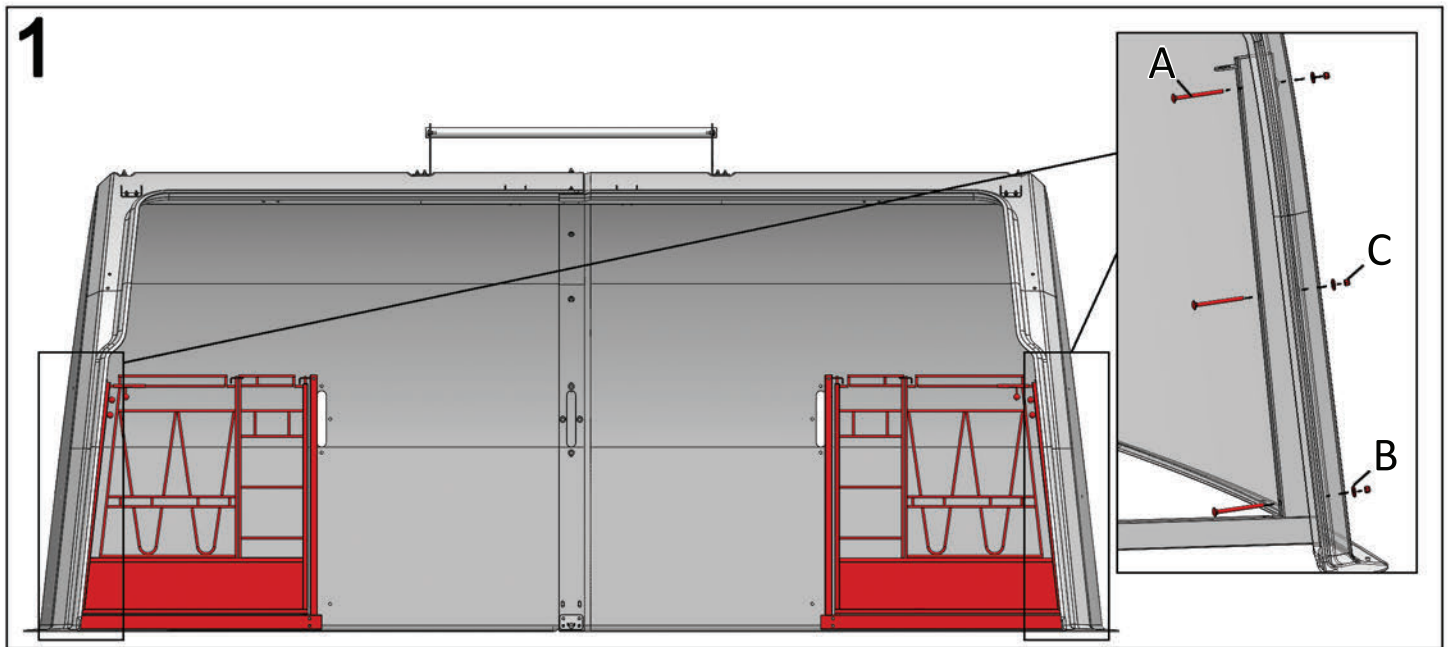

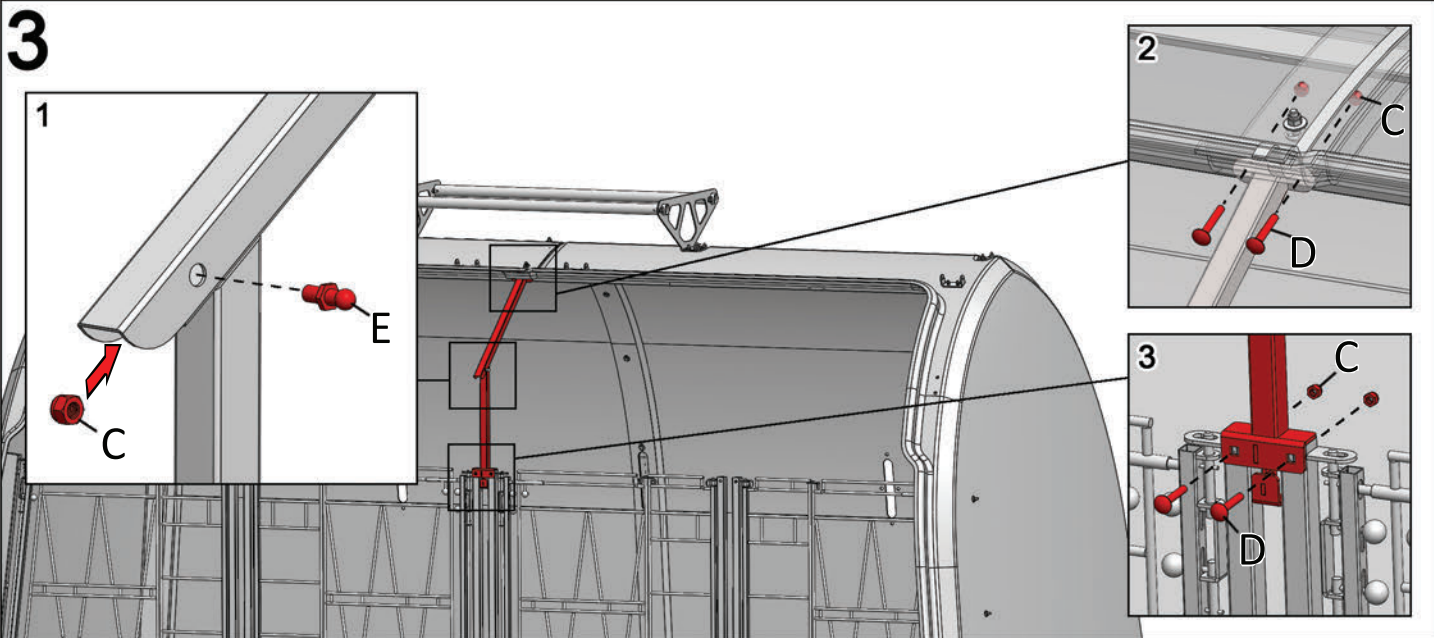







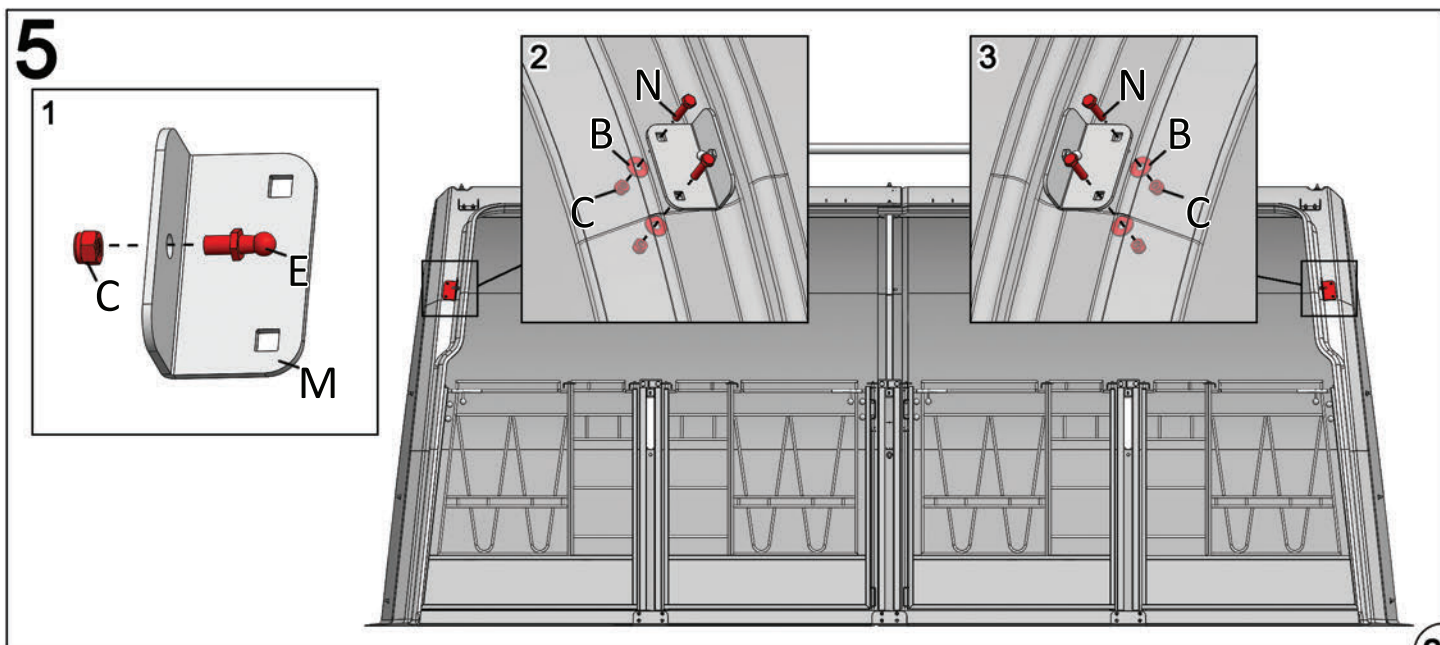
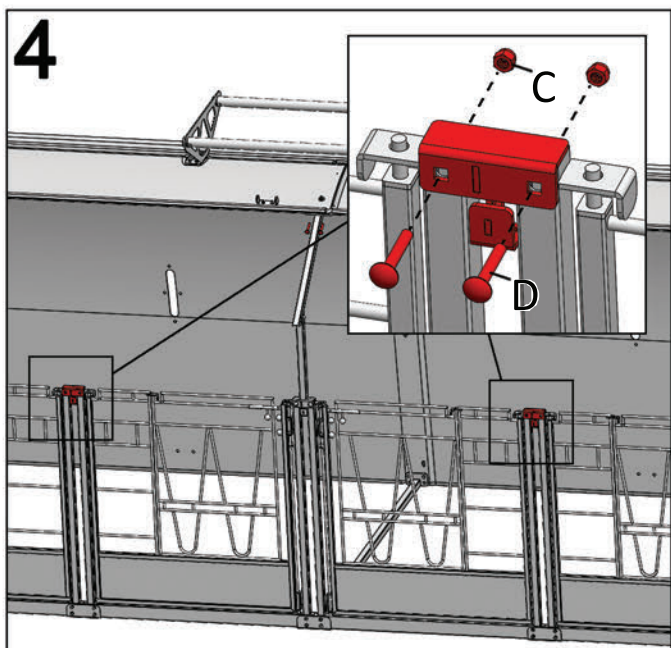

Art. Nr. 100250



© Rights reserved by VDK Products B.V. WWW.CALFOTEL.COM 01-2019



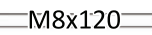
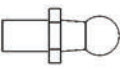

<b>5</b>		G  1x
A  M8x25	14x	H  1x
B 	10x	
C 	20x	
D  M8x120	4x	
E 	2x	
F 	4x	

Art. Nr. 100250

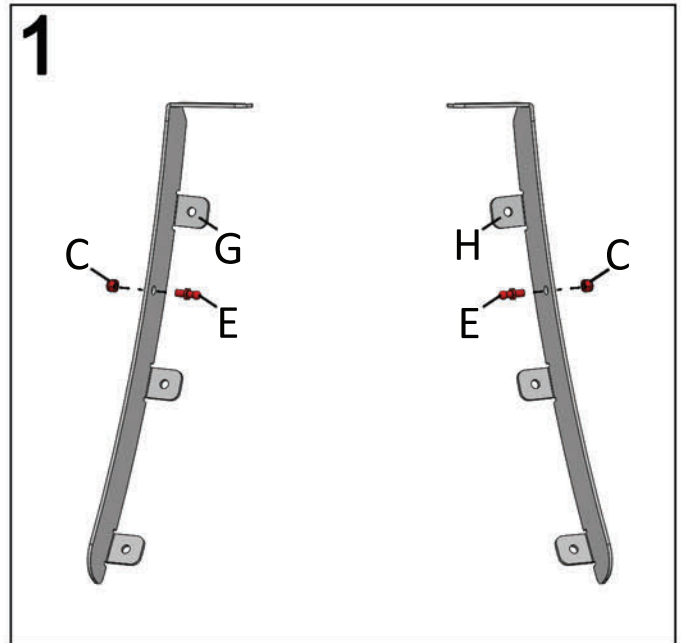

© Rights reserved by VDK Products B.V. WWW.CALFOTEL.COM 01-2019

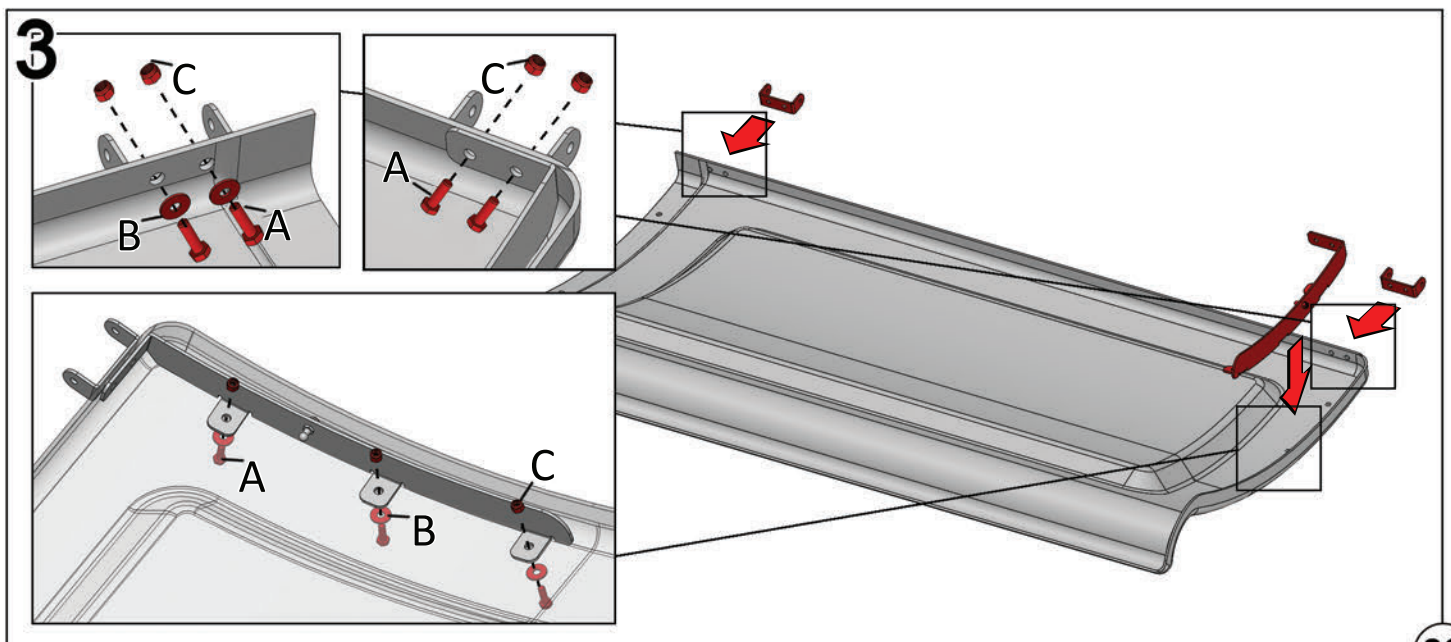
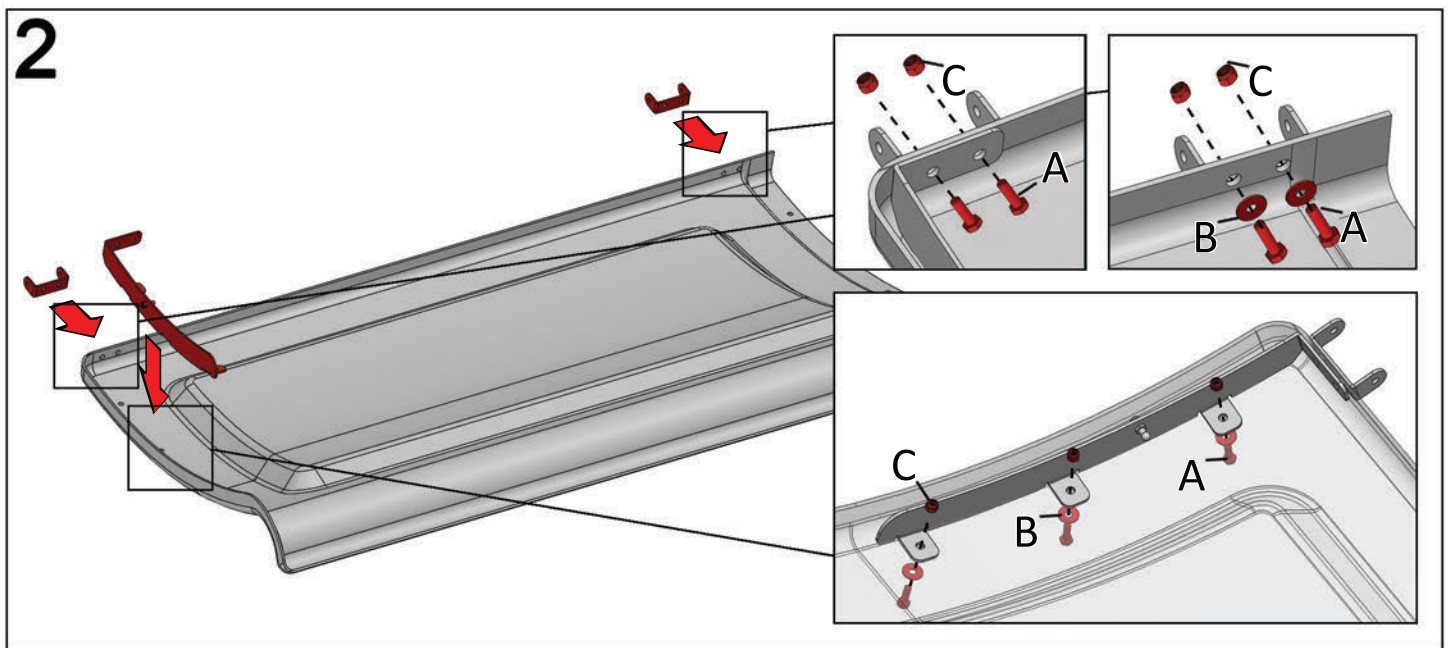

4

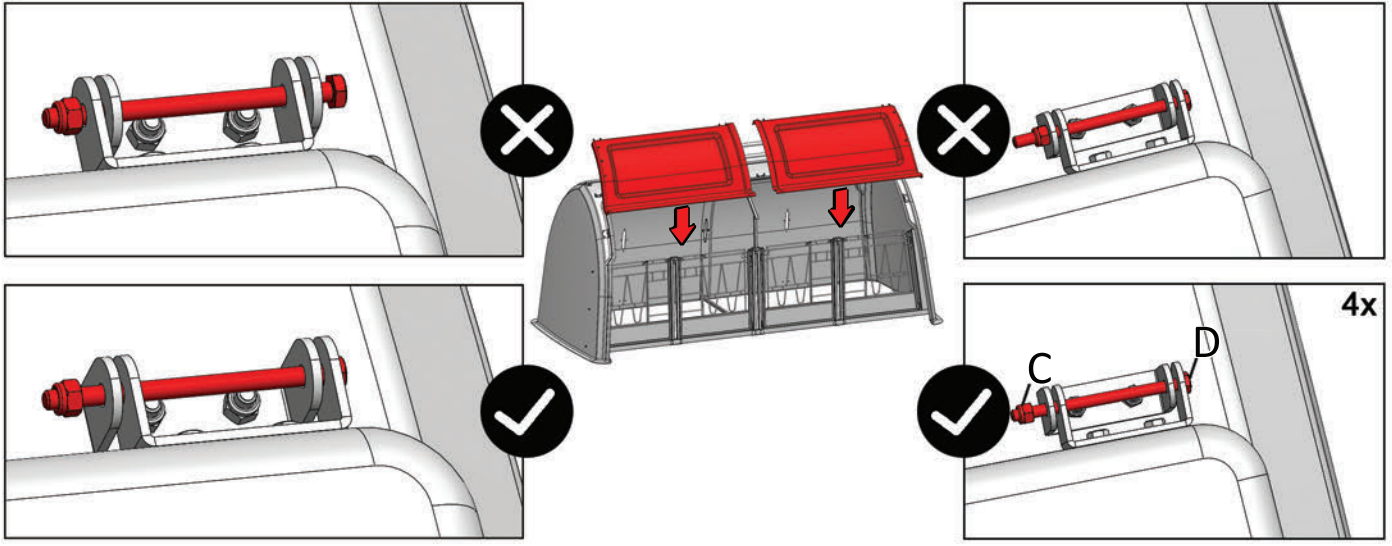









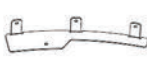

Art. Nr. 100250



© Rights reserved by VDK Products B.V. WWW.CALFOTEL.COM

01-2019





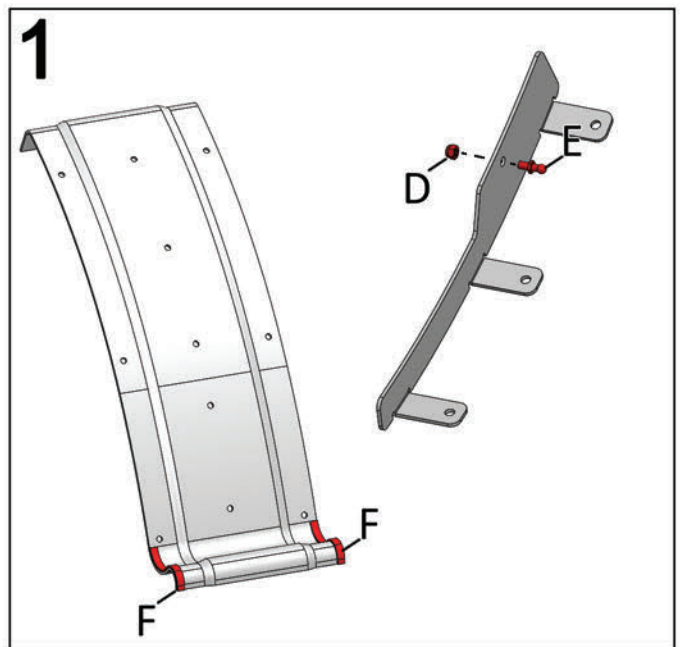

<b>6</b>			
A	 6x	G	 1x
B	 1x	H	 1x
C	 5x	J	 1x
D	 9x	K	 1x
E	 1x	L	 1x
F	 2x	M	 1x

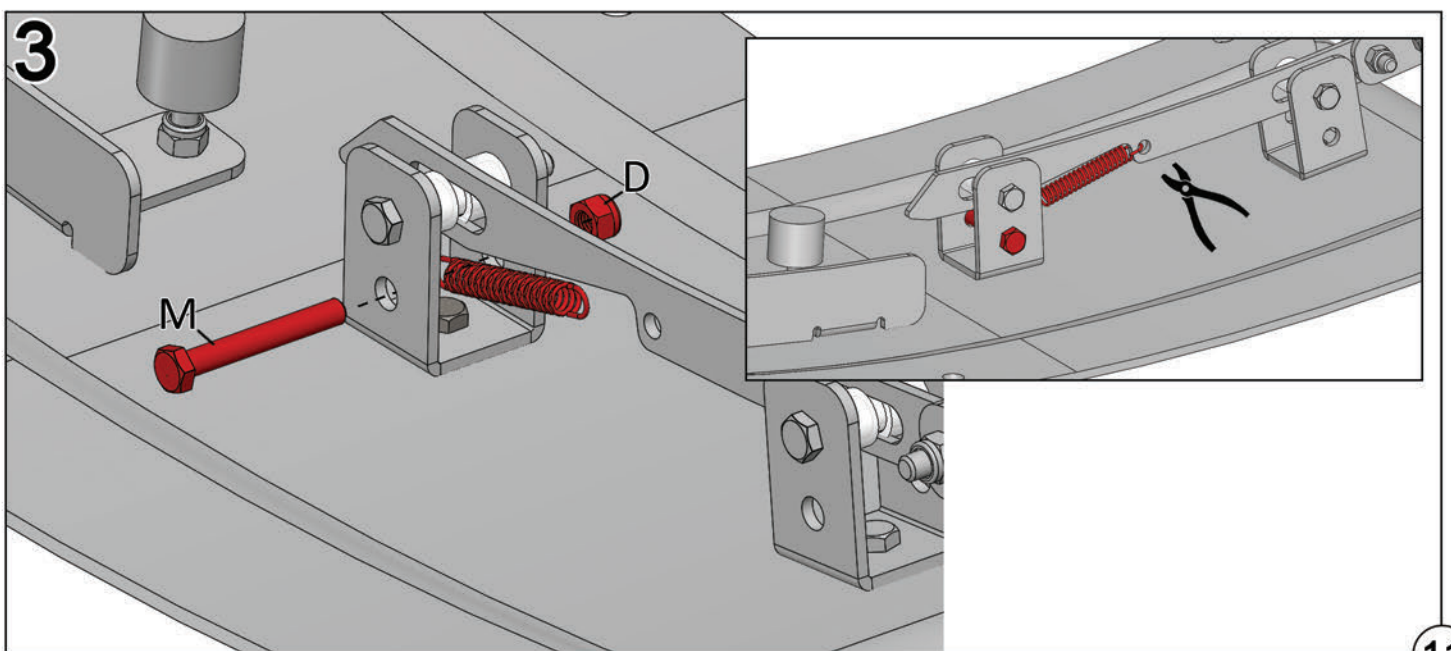
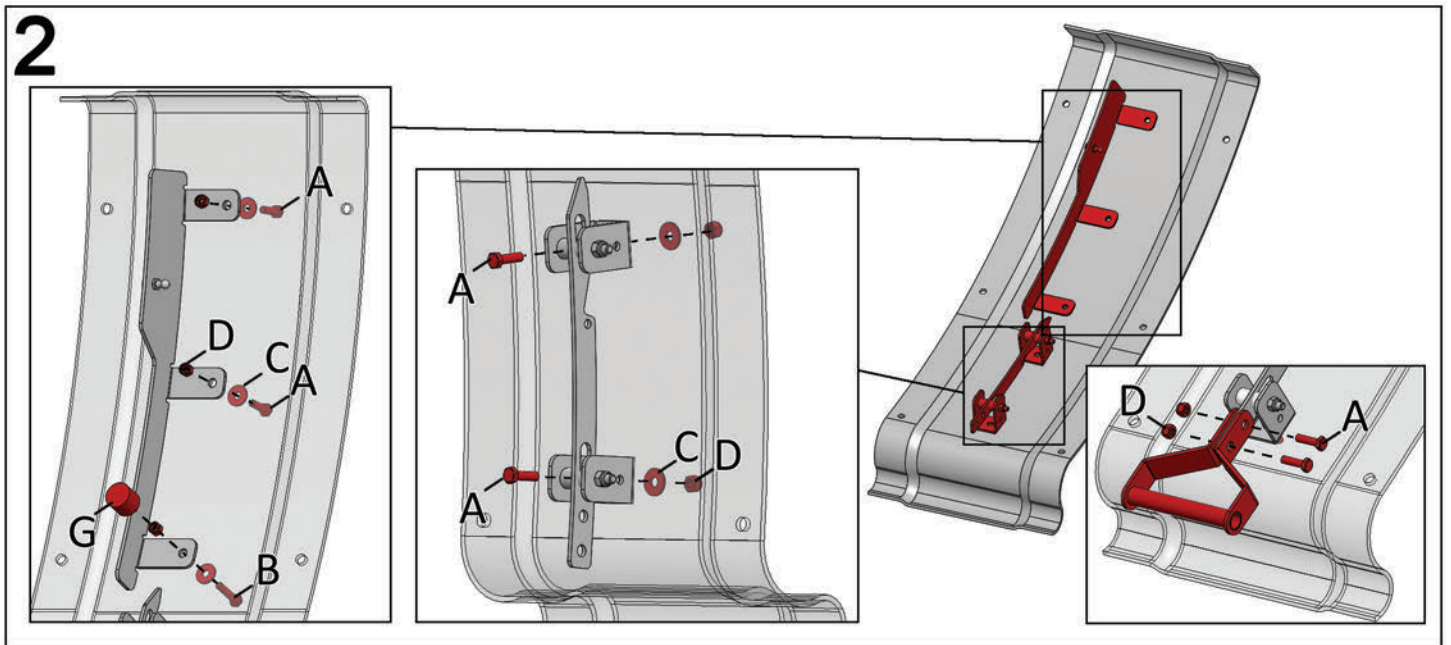
Art. Nr. 100250

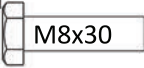
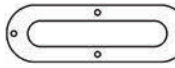

© Rights reserved by VDK Products B.V. WWW.CALFOTEL.COM 01-2019

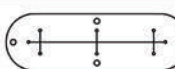

<b>7</b>			
A	 M8x30 22x	G	 2x
B	 30x	H	 1x
C	 22x		
D	 3x		
E	 3x		
F	 2x		

Art. Nr. 100250



© Rights reserved by VDK Products B.V. WWW.CALFOTEL.COM 01-2019

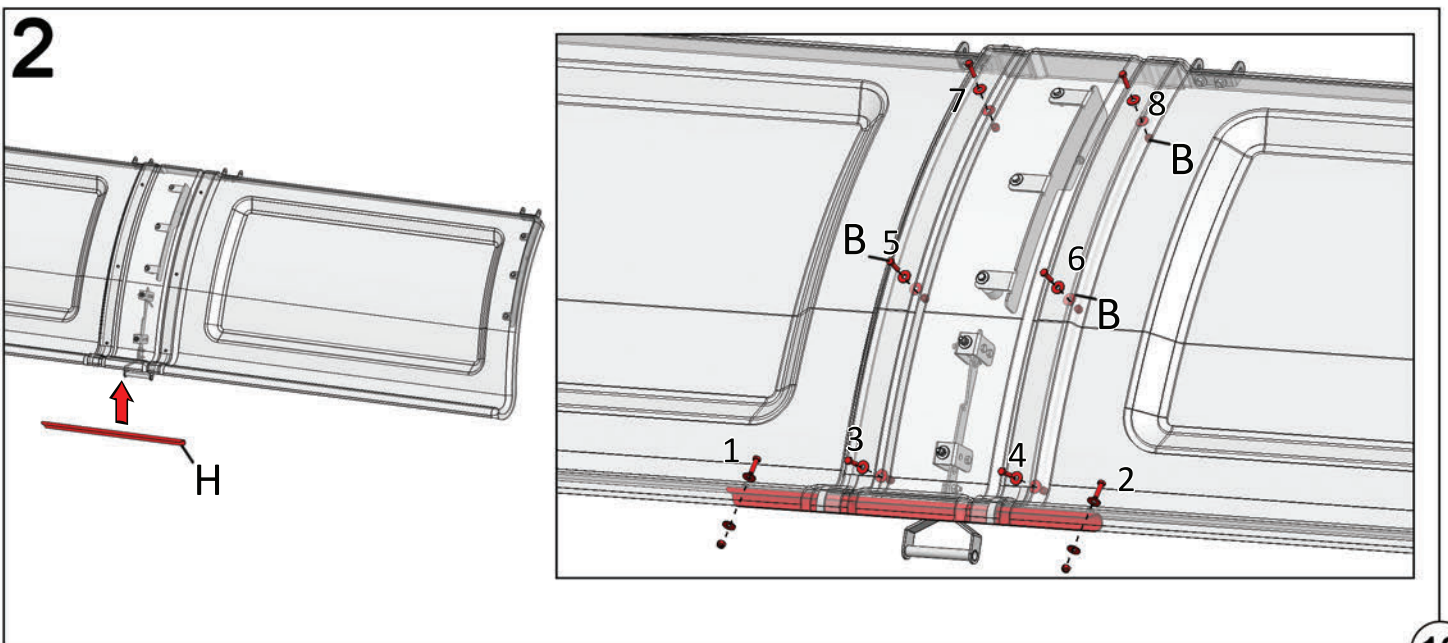
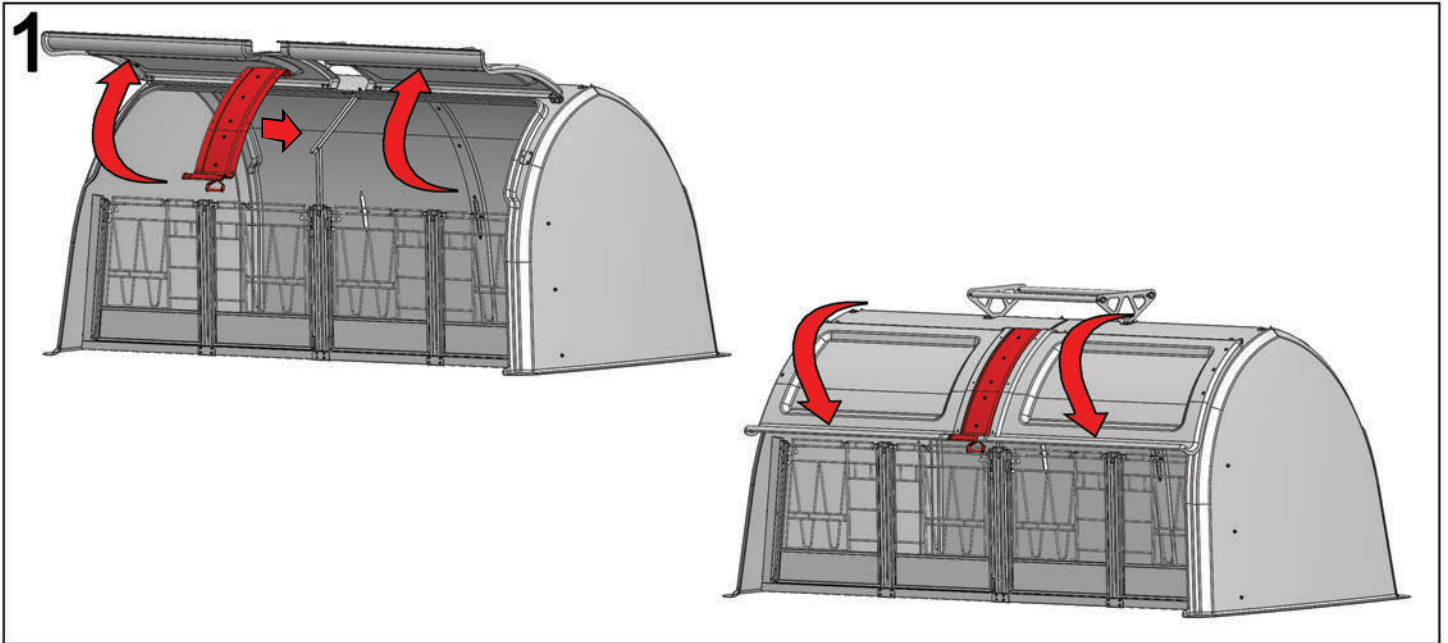

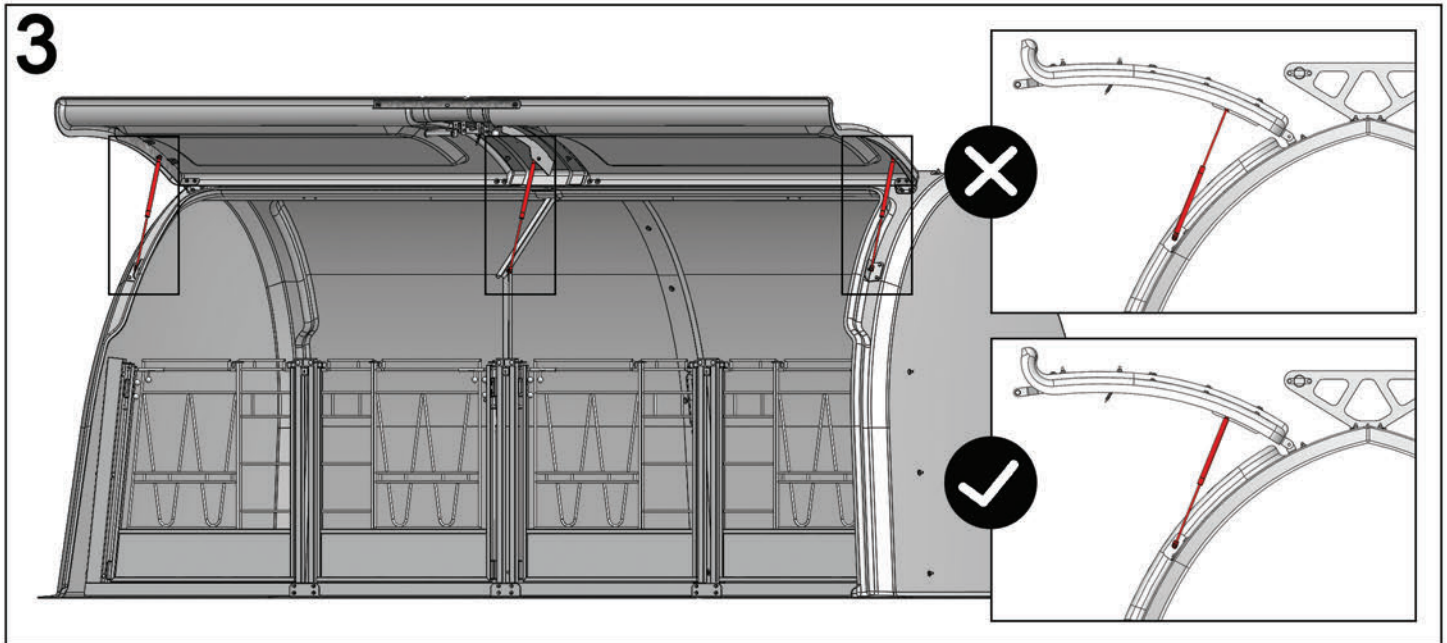

Art. Nr. 100250



© Rights reserved by VDK Products B.V. WWW.CALFOTEL.COM 01-2019

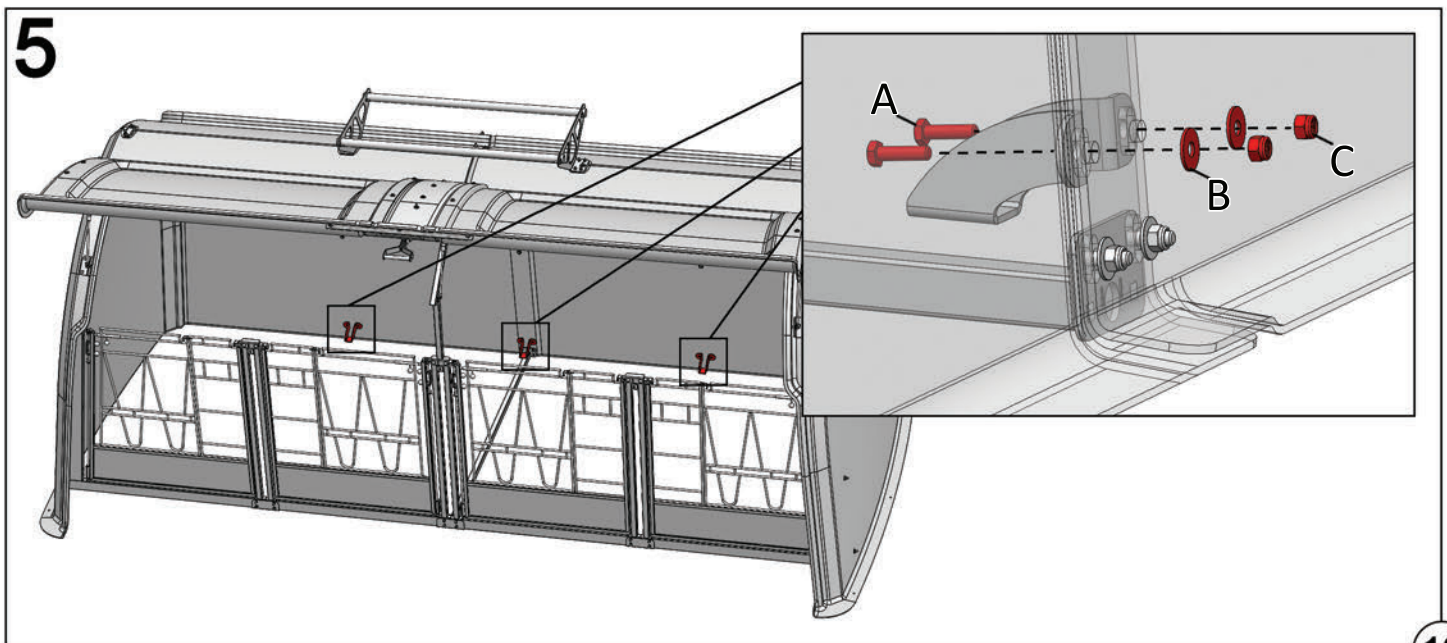
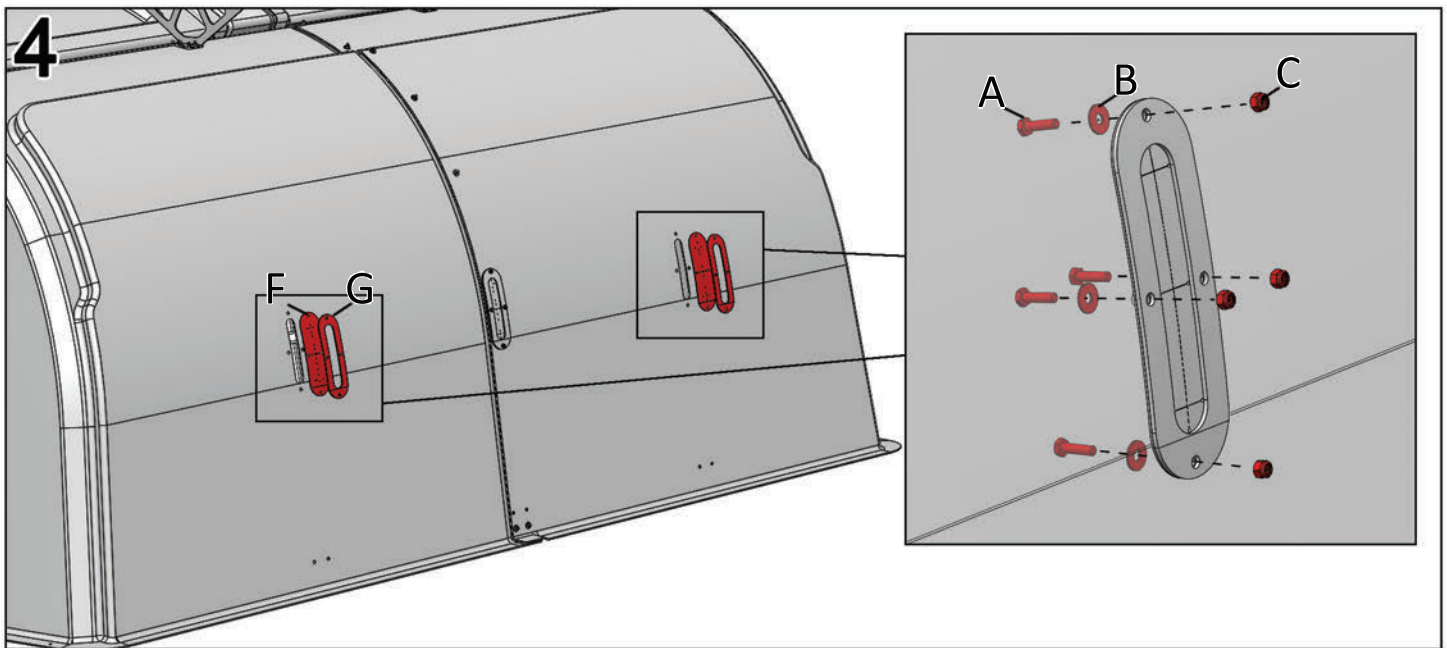

6

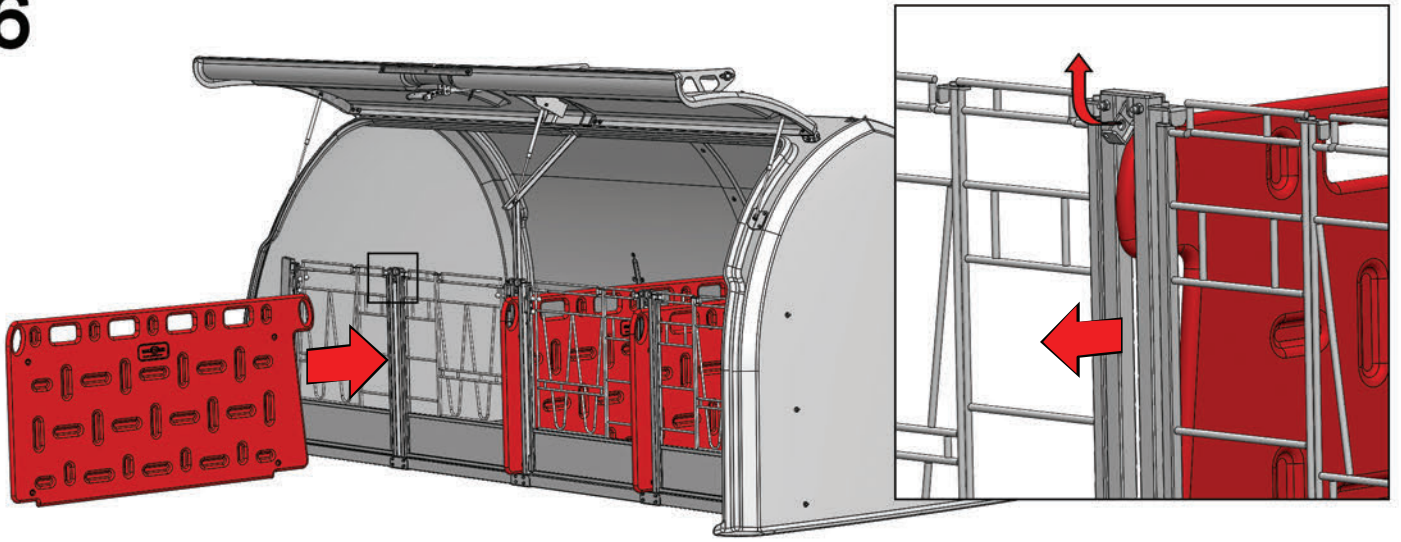

Art. Nr. 100250

**CALFOTEL**  
www.calfotel.com

© Rights reserved by VDK Products B.V. WWW.CALFOTEL.COM 01-2019

7

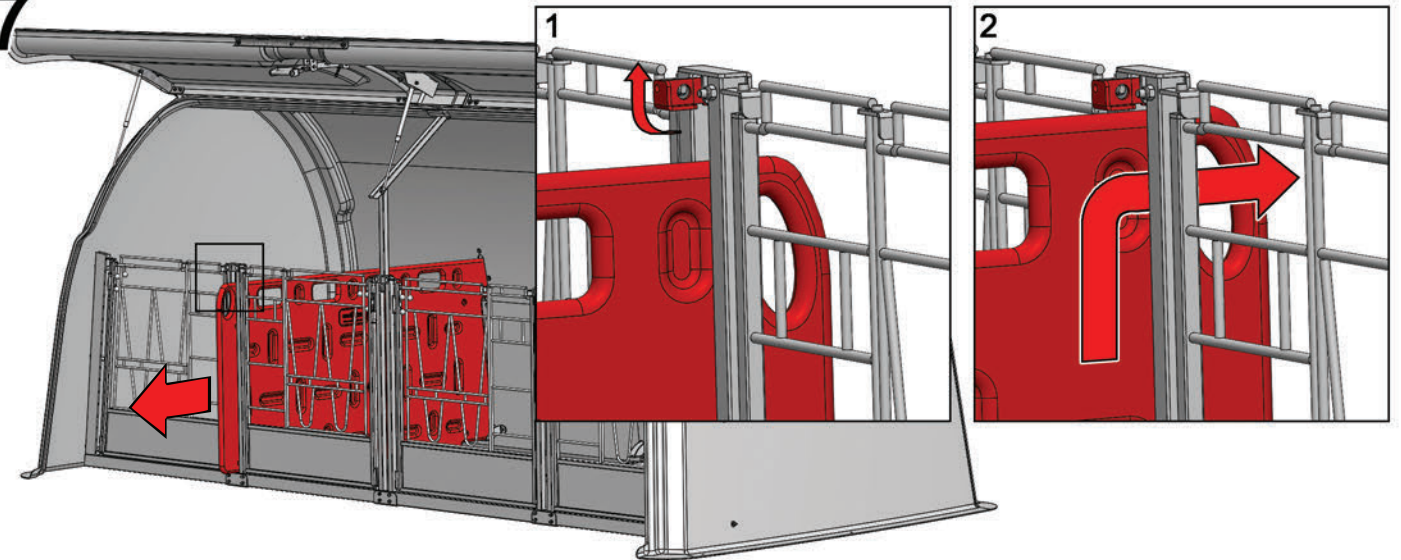



WARNING:  
CHECK FASTENERS BEFORE LIFTING &  
MOVING THE STABLE/HUTCH.



WAARSCHUWING:  
CONTROLEER ALLE BOUTEN EN MOEREN ALVORENS  
U DE STAL OPTILT EN VERPLAATST.

ATTENTION:  
AVANT DE SOULEVER ET DE DÉPLACER LA NICHE,  
VERIFIEZ D'ABORD TOUS LES BOULONS ET ÉCROUS.

ACHTUNG:  
ÜBERPRÜFEN SIE ZUERST ALLE SCHRAUBER UND  
MUTTERN, BEVOR SIE DEN STAU HEBEN UND BEWEGEN.

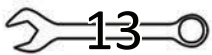
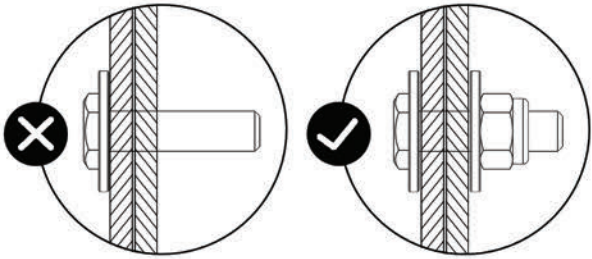

WARNING:  
DO NOT STAND NEAR OR UNDER THE  
STABLE/HUTCH WHEN LIFTING.



WAARSCHUWING:  
STA NIET DICHTBIJ OF ONDER DE STAL TIJDENS  
HET VERPLAATSEN.

ATTENTION:  
NE RESTEZ PAS TROP PRÈS OU SOUS LA NICHE PERDANT  
SON DÉPLACEMENT.

ACHTUNG:  
BLEIBEN SIE WÄHREND DER BEWEGUNG NICHT IN DER  
NÄHE ODER UNTER DEM STALL.

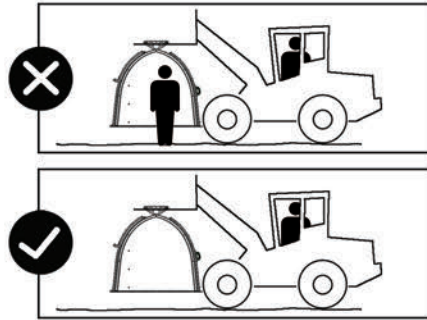

Art. Nr. 100250

**CALFOTEL**  
www.calfotel.com

© Rights reserved by VDK Products B.V. WWW.CALFOTEL.COM 01-2019

